



# Standard Test Methods for Flash Point by Pensky-Martens Closed Cup Tester<sup>1</sup>

This standard is issued under the fixed designation D 93; the number immediately following the designation indicates the year of original adoption or, in the case of revision, the year of last revision. A number in parentheses indicates the year of last reapproval. A superscript epsilon ( $\epsilon$ ) indicates an editorial change since the last revision or reapproval.

*This standard has been approved for use by agencies of the Department of Defense.*

## INTRODUCTION

This flash point test method is a dynamic test method and depends on definite rates of temperature increases to control the precision of the test method. The rate of heating may not in all cases give the precision quoted in the test method because of the low thermal conductivity of certain materials. To improve the prediction of flammability, Test Method D 3941, an equilibrium method, was developed in which the heating rate is slower. This allows the vapor above the test specimen and the test specimen to be at about the same temperature. If your specification requires Test Method D 93, do not substitute Test Method D 3941 or any other test method without obtaining comparative data and agreement from the specifier.

Flash point values are a function of the apparatus design, the condition of the apparatus used, and the operational procedure carried out. Flash point can therefore only be defined in terms of a standard test method, and no general valid correlation can be guaranteed between results obtained by different test methods, or with test apparatus different from that specified.

### 1. Scope \*

1.1 These test methods cover the determination of the flash point of petroleum products in the temperature range from 40 to 360°C by a manual Pensky-Martens closed-cup apparatus or an automated Pensky-Martens closed-cup apparatus.

NOTE 1—Flash point determination as above 250°C can be performed, however, the precisions have not been determined above this temperature. For residual fuels, precisions have not been determined for flash points above 100°C.

1.2 Procedure A is applicable to distillate fuels (diesel, kerosine, heating oil, turbine fuels), new lubricating oils, and other homogeneous petroleum liquids not included in the scope of Procedure B.

1.3 Procedure B is applicable to residual fuel oils, cutback residua, used lubricating oils, mixtures of petroleum liquids with solids, petroleum liquids that tend to form a surface film under test conditions, or are petroleum liquids of such kinematic viscosity that they are not uniformly heated under the stirring and heating conditions of Procedure A.

1.4 These test methods is applicable for the detection of contamination of relatively nonvolatile or nonflammable materials with volatile or flammable materials.

1.5 The values stated in SI units shall be regarded as the standard. The values given in parentheses are provided for information only.

1.6 *This standard does not purport to address all of the safety concerns, if any, associated with its use. It is the responsibility of the user of this standard to establish appropriate safety and health practices and determine the applicability of regulatory limitations prior to use.* For specific hazards statements, see 6.4, 7.1, 9.3, 9.4, 11.1.2, 11.1.4, and 12.1.2.

### 2. Referenced Documents

#### 2.1 ASTM Standards:

D 56 Test Methods for Flash Point by Tag Closed Cup Tester<sup>2</sup>

D 3941 Test Method for Flash Point by the Equilibrium Method with a Closed-Cup Apparatus<sup>3</sup>

D 4057 Practice for Manual Sampling for Petroleum and Petroleum Products<sup>4</sup>

<sup>1</sup> These test methods are under the joint jurisdiction of ASTM Committee D02 on Petroleum Products and Lubricants and are the direct responsibility of Subcommittee D02.08 on Volatility. In the IP, these test methods are under the jurisdiction of the Standardization Committee.

Current edition approved Dec. 10, 2002. Published March 2003. Originally approved in 1921. Last previous edition approved in 2002 as D 93–02.

<sup>2</sup> *Annual Book of ASTM Standards*, Vol 05.01.

<sup>3</sup> *Annual Book of ASTM Standards*, Vol 06.01.

<sup>4</sup> *Annual Book of ASTM Standards*, Vol 05.02.

\*A Summary of Changes section appears at the end of this standard.

D 4177 Practice for Automatic Sampling of Petroleum and Petroleum Products<sup>4</sup>

E 1 Specification for ASTM Thermometers<sup>5</sup>

E 300 Practice for Sampling Industrial Chemicals<sup>6</sup>

E 502 Test Method for Selection and Use of ASTM Standards for the Determination of Flash Point of Chemicals by Closed Cup Methods<sup>7</sup>

2.2 *ISO Standards*<sup>8</sup>

Guide 34 Quality Systems Guidelines for the Production of Reference Materials

Guide 35 Certification of Reference Material—General and Statistical Principles

### 3. Terminology

3.1 *Definitions:*

3.1.1 *dynamic, adj—in petroleum products*—the condition where the vapor above the test specimen and the test specimen are not in temperature equilibrium at the time that the ignition source is applied.

3.1.1.1 *Discussion*—This is primarily caused by the heating of the test specimen at the constant prescribed rate with the vapor temperature lagging behind the test specimen temperature.

3.1.2 *equilibrium, n—in petroleum products*—the condition where the vapor above the test specimen and the test specimen are at the same temperature at the time the ignition source is applied.

3.1.2.1 *Discussion*—This condition may not be fully achieved in practice, since the temperature may not be uniform throughout the test specimen, and the test cover and shutter on the apparatus can be cooler.

3.1.3 *flash point, n—in petroleum products*, the lowest temperature corrected to a barometric pressure of 101.3 kPa (760 mm Hg), at which application of an ignition source causes the vapors of a specimen of the sample to ignite under specified conditions of test.

3.1.3.1 *Discussion*—The test specimen is deemed to have flashed when a flame appears and instantaneously propagates itself over the entire surface of the test specimen.

3.1.3.2 *Discussion*—When the ignition source is a test flame, the application of the test flame may cause a blue halo or an enlarged flame prior to the actual flash point. This is not a flash point and shall be ignored.

### 4. Summary of Test Method

4.1 A brass test cup of specified dimensions, filled to the inside mark with test specimen and fitted with a cover of specified dimensions, is heated and the specimen stirred at specified rates, by either of two defined procedures (A or B). An ignition source is directed into the test cup at regular intervals with simultaneous interruption of the stirring, until a flash is detected (see 3.1.3.1). The flash point is reported as defined in 3.1.3.

### 5. Significance and Use

5.1 The flash point temperature is one measure of the tendency of the test specimen to form a flammable mixture with air under controlled laboratory conditions. It is only one of a number of properties which must be considered in assessing the overall flammability hazard of a material.

5.2 Flash point is used in shipping and safety regulations to define *flammable* and *combustible* materials. One should consult the particular regulation involved for precise definitions of these classifications.

NOTE 2—The U.S. Department of Transportation (DOT)<sup>9</sup> and U.S. Department of Labor (OSHA) have established that liquids with a flash point under 37.8°C (100°F) are flammable, as determined by these test methods, for those liquids which have a kinematic viscosity of 5.8 mm<sup>2</sup>/s (cSt) or more at 37.8°C or 9.5 mm<sup>2</sup>/s (cSt) or more at 25°C (77°F), or that contain suspended solids, or have a tendency to form a surface film while under test. Other classification flash points have been established by these departments for liquids using these test methods.

5.3 These test methods should be used to measure and describe the properties of materials, products, or assemblies in response to heat and an ignition source under controlled laboratory conditions and should not be used to describe or appraise the fire hazard or fire risk of materials, products, or assemblies under actual fire conditions. However, results of these test methods may be used as elements of a fire risk assessment which takes into account all of the factors which are pertinent to an assessment of the fire hazard of a particular end use.

5.4 These test methods provides the only closed cup flash point test procedures for temperatures up to 370°C (698°F).

### 6. Apparatus

6.1 *Pensky-Martens Closed Cup Apparatus (manual)*—This apparatus consists of the test cup, test cover and shutter, stirring device, heating source, ignition source device, air bath, and top plate described in detail in Annex A1. The assembled manual apparatus, test cup, test cup cover, and test cup assembly are illustrated in Figs. A1.1-A1.4, respectively. Dimensions are listed respectively.

6.2 *Pensky-Martens Closed Cup Apparatus (automated)*—This apparatus is an automated flash point instrument that is capable of performing the test in accordance with Section 11 (Procedure A) and Section 12 (Procedure B) of these test methods. The apparatus shall use the test cup, test cover and shutter, stirring device, heating source, and ignition source device described in detail in Annex A1.

6.3 *Temperature Measuring Device*—Is a thermometer having a range as shown as follows and conforming to the requirements prescribed in Specification E 1 or in Annex A3, or an electronic temperature measuring device, such as resistance thermometers or thermocouples. The device shall exhibit the same temperature response as the mercury thermometers.

<sup>5</sup> *Annual Book of ASTM Standards*, Vol 14.03.

<sup>6</sup> *Annual Book of ASTM Standards*, Vol 15.05.

<sup>7</sup> *Annual Book of ASTM Standards*, Vol 14.02.

<sup>8</sup> Available from American National Standards Institute (ANSI), 25 W. 43rd St., 4th Floor, New York, NY 10036.

<sup>9</sup> For information on U.S. Department of Transportation regulations, see Codes of U.S. Regulations 49 CFR Chapter 1 and the U.S. Department of Labor, see 29 CFR Chapter XVII. Each of these items is revised annually and may be procured from the Superintendent of Documents, Government Printing Office, Washington, DC 20402.



Temperature Range	Thermometer Number	
	ASTM	IP
-5 to +110°C (20 to 230°F)	9C (9F)	15C
+10 to 200°C (50 to 392°F)	88C (88F)	101C
+90 to 370°C (200 to 700°F)	10C (10F)	16C

6.4 *Ignition Source*—Natural gas flame, bottled gas flame, and electric ignitors (hot wire) have been found acceptable for use as the ignition source. The gas flame device described in detailed in Fig. A1.4 requires the use of the pilot flame described in A1.1.2.3. The electric ignitors shall be of the hot-wire type and shall position the heated section of the ignitor in the aperture of the test cover in the same manner as the gas flame device. (**Warning**—Gas pressure supplied to the apparatus should not be allowed to exceed 3 kPa (12 in.) of water pressure.)

## 7. Reagents and Materials

7.1 *Cleaning Solvents*—Use suitable solvent capable of cleaning out the specimen from the test cup and drying the test cup and cover. Some commonly used solvents are toluene and acetone. (**Warning**—Toluene, acetone, and many solvents are flammable and a health hazard. Dispose of solvents and waste material in accordance with local regulations.)

## 8. Sampling

8.1 Obtain a sample in accordance with instructions given in Practices D 4057, D 4177, or E 300.

8.2 At least 75 mL of sample is required for each test. Refer to Practice D 4057. When obtaining a sample of residual fuel oil, the sample container shall be from 85 to 95 % full. For other types of samples, the size of the container shall be chosen such that the container is not more than 85 % full or less than 50 % full prior to any sample aliquot being taken.

8.3 Successive test specimens can be taken from the same sample container. Repeat tests have been shown to be within the precisions of the method when the second specimen is taken with the sample container at least 50 % filled. The results of flash point determinations can be affected if the sample volume is less than 50 % of sample container capacity.

8.4 Erroneously high flash points may be obtained if precautions are not taken to avoid the loss of volatile material. Do not open containers unnecessarily, to prevent loss of volatile material or possible introduction of moisture, or both. Avoid storage of samples at temperatures in excess of 35°C or 95°F. Samples for storage shall be capped tightly with inner seals. Do not make a transfer unless the sample temperature is at least the equivalent of 18°C or 32°F below the expected flash point.

8.5 Do not store samples in gas-permeable containers, since volatile material may diffuse through the walls of the enclosure. Samples in leaky containers are suspect and not a source of valid results.

8.6 Samples of very viscous materials shall be heated in their containers, with lid/cap slightly loosened to avoid buildup of dangerous pressure, at the lowest temperature adequate to liquefy any solids, not exceeding 28°C or 50°F below the expected flash point, for 30 min. If the sample is then not completely liquefied, extend the heating period for additional 30 min periods as necessary. Then gently agitate the sample to provide mixing, such as orbiting the container horizontally,

before transferring to the specimen cup. No sample shall be heated and transferred unless its temperatures is more than 18°C or 32°F below its expected flash point. When the sample has been heated above this temperature, allow the sample to cool until its temperature is at least 18°C or 32°F below the expected flash point before transferring.

NOTE 3—Volatile vapors can escape during heating when the sample container is not properly sealed.

NOTE 4—Some viscous samples may not completely liquefy even after prolonged periods of heating. Care should be exercised when increasing the heating temperature to avoid unnecessary loss of volatile vapors, or heating the sample too close to the flash point.

8.7 Samples containing dissolved or free water may be dehydrated with calcium chloride or by filtering through a qualitative filter paper or a loose plug of dry absorbent cotton. Warming the sample is permitted, but it shall not be heated for prolonged periods or greater than a temperature of 18°C 32°F below its expected flash point.

NOTE 5—If the sample is suspected of containing volatile contaminants, the treatment described in 8.6 and 8.7 should be omitted.

## 9. Preparation of Apparatus

9.1 Support the manual or automated apparatus on a level steady surface, such as a table.

9.2 Tests are to be performed in a draft-free room or compartment. Tests made in a laboratory hood or in any location where drafts occur are not reliable.

NOTE 6—A shield, of the approximate dimensions 460 mm (18 in.) square and 610 mm (24 in.) high, or other suitable dimensions, and having an open front is recommended to prevent drafts from disturbing the vapors above the test cup.

NOTE 7—With some samples whose vapors or products of pyrolysis are objectionable, it is permissible to place the apparatus along with a draft shield in a ventilation hood, the draft of which is adjustable so that vapors can be withdrawn without causing air currents over the test cup during the ignition source application period.

9.3 Prepare the manual apparatus or the automated apparatus for operation in accordance with the manufacturer's instructions for calibrating, checking, and operating the equipment. (**Warning**—Gas pressure should not be allowed to exceed 3 kPa (12 in.) of water pressure.)

9.4 Thoroughly clean and dry all parts of the test cup and its accessories before starting the test, to ensure the removal of any solvent which had been used to clean the apparatus. Use suitable solvent capable of removing all of the specimen from the test cup and drying the test cup and cover. Some commonly used solvents are toluene and acetone. (**Warning**—Toluene, acetone, and many solvents are flammable. Health hazard. Dispose of solvents and waste material in accordance with local regulations.)

## 10. Verification of Apparatus

10.1 Adjust the automated flash point detection system (when used) in accordance with the manufacturer's instructions.

10.2 Verify that the temperature measuring device is in accordance with 6.3.

10.3 Verify the performance of the manual apparatus or the automated apparatus at least once per year by determining the



flash point of a certified reference material (CRM) such as those listed in Annex A4, which is reasonably close to the expected temperature range of the samples to be tested. The material shall be tested according to Procedure A of these test methods and the observed flash point obtained in 11.1.8 or 11.2.2 shall be corrected for barometric pressure (see Section 13). The flash point obtained shall be within the limits stated in Table A4.1 for the identified CRM or within the limits calculated for an unlisted CRM (see Annex A4).

10.4 Once the performance of the apparatus has been verified, the flash point of secondary working standards (SWSs) can be determined along with their control limits. These secondary materials can then be utilized for more frequent performance checks (see Annex A4).

10.5 When the flash point obtained is not within the limits stated in 10.3 or 10.4, check the condition and operation of the apparatus to ensure conformity with the details listed in Annex A1, especially with regard to tightness of the lid (A1.1.2.2), the action of the shutter, the position of the ignition source (A1.1.2.3), and the angle and position of the temperature measuring device (A1.1.2.4). After any adjustment, repeat the test in 10.3 using a fresh test specimen, with special attention to the procedural details prescribed in these test methods.

## PROCEDURE A

### 11. Procedure

#### 11.1 Manual Apparatus:

11.1.1 Ensure that the sample container is filled to the volume capacity requirement specified in 8.2. Fill the test cup with the test specimen to the filling mark inside of the test cup. The temperature of the test cup and test specimen shall be at least 18°C or 32°F below the expected flash point. If too much test specimen has been added to the test cup, remove the excess using a syringe or similar device for withdrawal of fluid. Place the test cover on the test cup and place the assembly into the apparatus. Be sure the locating or locking device is properly engaged. If the temperature measuring device is not already in place, insert the device into its holder.

11.1.2 Light the test flame, and adjust it to a diameter of 3.2 to 4.8 mm (0.126 to 0.189 in.), or switch on the electric igniter and adjust the intensity in accordance with the manufacturer's instructions. (**Warning**—Gas pressure should not be allowed to exceed 3 kPa (12 in.) of water pressure.) (**Warning**—Exercise care when using a gas test flame. If it should be extinguished it will not ignite the vapors in the test cup, and the gas for the test flame that then enters the vapor space can influence the result.) (**Warning**—The operator should exercise and take appropriate safety precautions during the initial application of the ignition source, since test specimens containing low-flash material can give an abnormally strong flash when the ignition source is first applied.) (**Warning**—The operator should exercise and take appropriate safety precautions during the performance of these test methods. The temperatures attained during these test methods, up to 370°C (698°F), are considered hazardous.)

11.1.3 Apply the heat at such a rate that the temperature, as indicated by the temperature measuring device, increases 5 to 6°C (9 to 11°F)/min.

11.1.4 Turn the stirring device at 90 to 120 rpm, stirring in a downward direction. (**Warning**—Meticulous attention to all details relating to the ignition source, size of test flame or intensity of the electric ignitor, rate of temperature increase, and rate of dipping the ignition source into the vapor of the test specimen is desirable for good results.)

#### 11.1.5 Application of Ignition Source:

11.1.5.1 If the test specimen is expected to have a flash point of 110°C or 230°F or below, apply the ignition source when the temperature of the test specimen is  $23 \pm 5^\circ\text{C}$  or  $41 \pm 9^\circ\text{F}$  below the expected flash point and each time thereafter at a temperature reading that is a multiple of 1°C or 2°F. Discontinue the stirring of the test specimen and apply the ignition source by operating the mechanism on the test cover which controls the shutter so that the ignition source is lowered into the vapor space of the test cup in 0.5 s, left in its lowered position for 1 s, and quickly raised to its upward position.

11.1.5.2 If the test specimen is expected to have a flash point above 110°C or 230°F, apply the ignition source in the manner described in 11.1.5.1 at each temperature increase of 2°C or 5°F, beginning at a temperature of  $23 \pm 5^\circ\text{C}$  or  $41 \pm 9^\circ\text{F}$  below the expected flash point.

11.1.6 When testing materials to determine if volatile material contamination is present, it is not necessary to adhere to the temperature limits for initial ignition source application as stated in 11.1.5.

11.1.7 When testing materials where the expected flash point temperature is not known, bring the material to be tested and the tester to a temperature of  $15 \pm 5^\circ\text{C}$  or  $60 \pm 10^\circ\text{F}$ . When the material is known to be very viscous at this temperature, heat the specimen to a starting temperature as described in 8.6. Apply the ignition source, in the manner described in 11.1.5.1, beginning at least 5°C or 10°F higher than the starting temperature.

NOTE 8—Flash Point results determined in an “unknown expected flash point mode” should be considered approximate. This value can be used as the expected flash point when a fresh specimen is tested in the standard mode of operation.

11.1.8 Record as the observed flash point the reading on the temperature measuring device at the time ignition source application causes a distinct flash in the interior of the test cup. The sample is deemed to have flashed when a large flame appears and instantaneously propagates itself over the entire surface of the test specimen. (**Warning**—For certain mixtures containing halogenated hydrocarbons, such as, methylene chloride or trichloroethylene, no distinct flash, as defined, is observed. Instead a significant enlargement of the test flame (not halo effect) and change in color of the test flame from blue to yellowish-orange occurs. Continued heating and testing of these samples above ambient temperature can result in significant burning of vapors outside the test cup, and can be a potential fire hazard. See Appendix X1 and Appendix X2 for more information.)

11.1.9 When the ignition source is a test flame, the application of the test flame may cause a blue halo or an enlarged flame prior to the actual flash point. This is not a flash and shall be ignored.

11.1.10 When a flash point is detected on the first application, the test shall be discontinued, the result discarded, and the test repeated with a fresh test specimen. The first application of the ignition source with the fresh test specimen shall be  $23 \pm 5^\circ\text{C}$  or  $41 \pm 9^\circ\text{F}$  below the temperature at which a flash point was detected on the first application.

11.1.11 When a flash point is detected at a temperature which is greater than  $28^\circ\text{C}$  or  $50^\circ\text{F}$  above the temperature of the first application of the ignition source, or when a flash point is detected at a temperature which is less than  $18^\circ\text{C}$  or  $32^\circ\text{F}$  above the temperature of the first application of the ignition source, the result shall be considered approximate, and the test repeated with a fresh test specimen. Adjust the expected flash point for this next test to the temperature of the approximate result. The first application of the ignition source with the fresh test specimen shall be  $23 \pm 5^\circ\text{C}$  or  $41 \pm 9^\circ\text{F}$  below the temperature at which the approximate result was found.

11.1.12 When the apparatus has cooled down to a safe handling temperature, less than  $55^\circ\text{C}$  ( $130^\circ\text{F}$ ), remove the test cover and the test cup and clean the apparatus as recommended by the manufacturer.

NOTE 9—Exercise care when cleaning and positioning the lid assembly so not to damage or dislocate the flash detection system or temperature measuring device. See the manufacturer’s instructions for proper care and maintenance.

#### 11.2 Automated Apparatus:

11.2.1 The automated apparatus shall be capable of performing the procedure as described in 11.1, including control of the heating rate, stirring of the test specimen, application of the ignition source, detection of the flash point, and recording the flash point.

11.2.2 Start the automated apparatus in accordance with the manufacturer’s instructions. The apparatus shall follow the procedural details described in 11.1.3 through 11.1.8.

### PROCEDURE B

#### 12. Procedure

##### 12.1 Manual Apparatus:

12.1.1 Ensure that the sample container is filled to the volume capacity requirement specified in 8.2. Fill the test cup with the test specimen to the filling mark inside of the test cup. The temperature of the test cup and test specimen shall be at least  $18^\circ\text{C}$  or  $32^\circ\text{F}$  below the expected flash point. If too much test specimen has been added to the test cup, remove the excess using a syringe or similar device for withdrawal of fluid. Place the test cover on the test cup and place the assembly into the apparatus. Be sure the locating or locking device is properly engaged. If the temperature measuring device is not already in place, insert the device into its holder.

12.1.2 Light the test flame and adjust it to a diameter of 3.2 to 4.8 mm (0.126 to 0.189 in.), or switch on the electric igniter and adjust the intensity in accordance with the manufacturer’s instructions. (**Warning**—Gas pressure should not be allowed to exceed 3 kPa (12 in.) of water pressure.) (**Warning**—Exercise care when using a gas test flame. If it should be extinguished it will not ignite the vapors in the test cup and the gas for the test flame that then enters the vapor space can influence the result.) (**Warning**—The operator should exercise

and take appropriate safety precautions during the initial application of the ignition source, since test specimens containing low-flash material may give an abnormally strong flash when the ignition source is first applied.) (**Warning**—The operator should exercise and take appropriate safety precautions during the performance of these test methods. The temperatures attained during these test methods, up to  $370^\circ\text{C}$  ( $698^\circ\text{F}$ ), are considered hazardous.)

12.1.3 Turn the stirring device at  $250 \pm 10$  rpm, stirring in a downward direction.

12.1.4 Apply the heat at such a rate that the temperature as indicated by the temperature measuring device increases 1 to  $1.6^\circ\text{C}$  (2 to  $3^\circ\text{F}$ )/min.

12.1.5 Proceed as prescribed in Section 11, with the exception of the preceding requirements for rates of stirring and heating.

#### 12.2 Automated Apparatus:

12.2.1 The automated apparatus shall be capable of performing the procedure as described in 12.1, including control of the heating rate, stirring of the test specimen, application of the ignition source, detection of the flash point, and recording the flash point.

12.2.2 Start the automated apparatus in accordance with the manufacturer’s instructions. The apparatus shall follow the procedural details in accordance with 12.1.3 through 12.1.5.

### PRECISION, CALCULATION, AND REPORT FOR PROCEDURES A AND B

#### 13. Calculation

13.1 Observe and record the ambient barometric pressure (see Note 10) at the time of the test. When the pressure differs from 101.3 kPa (760 mm Hg), correct the flash point as follows:

$$\text{Corrected flash point} = C + 0.25 (101.3 - K) \quad (1)$$

$$\text{Corrected flash point} = F + 0.06 (760 - P) \quad (2)$$

$$\text{Corrected flash point} = C + 0.033 (760 - P) \quad (3)$$

where:

$C$  = observed flash point,  $^\circ\text{C}$ ,

$F$  = observed flash point,  $^\circ\text{F}$ ,

$P$  = ambient barometric pressure, mm Hg, and

$K$  = ambient barometric pressure, kPa.

NOTE 10—The barometric pressure used in this calculation is the ambient pressure for the laboratory at the time of the test. Many aneroid barometers, such as those used at weather stations and airports, are precorrected to give sea level readings and would not give the correct reading for this test.

13.2 After correction for barometric pressure, round the temperature to the nearest  $0.5^\circ\text{C}$  ( $1^\circ\text{F}$ ) and record.

#### 14. Report

14.1 Report the corrected flash point as the ASTM D 93–IP 34, Procedure A or Procedure B Pensky-Martens Closed Cup Flash Point of the test specimen.

## 15. Precision and Bias (Procedure A)

15.1 *Precision*—The precision of this procedure as determined by the statistical examination of the interlaboratory test results, is as follows:

15.1.1 *Repeatability*—The difference between successive results, obtained by the same operator with the same apparatus under constant operating conditions on identical test material, would in the long run, in the normal and correct operation of the test method, exceed the following values in 1 case in 20.

$$r = AX, \quad (4)$$

$$A = 0.029,$$

$X$  = mean result in °C, and

$r$  = repeatability.

15.1.2 *Reproducibility*—The difference between two single and independent results, obtained by different operators working in different laboratories on identical material, would in the long run, in the normal and correct operation of the test method, exceed the following values only in 1 case in 20.

$$R = BX, \quad (5)$$

$$B = 0.071,$$

$X$  = mean result in °C, and

$R$  = reproducibility.

15.1.3 *Bias*—Since there is no accepted reference material suitable for determining the bias for the procedure in these test methods, bias has not been determined.

15.1.4 *Relative Bias*—Statistical evaluation of the data did not detect any significant difference between the reproducibility variances of manual and automated Pensky-Martens flash point results for the samples studied. Evaluation of the data did not detect any significant difference between averages of manual and automated Pensky-Martens flash point for the samples studied with the exception of cycle oil and fuel oil which showed some bias. In any case of dispute, the manual procedure shall be considered the referee test.

NOTE 11—The precision statements were derived on clear liquids only. Refer to the research report<sup>10</sup> for information regarding relative bias and types of samples. Additional studies are in progress concerning relative bias.

15.1.5 The precision data were developed from a combined 1991 ASTM cooperative test program<sup>10</sup> using 5 samples of fuel and lubricating oils (Twelve laboratories participated with the

manual apparatus and 21 laboratories participated with the automated equipment) and a 1994 IP cooperative test program using 12 fuel samples and 4 pure chemicals. (Twenty-six laboratories participated with manual and automated equipment. The apparatus used either a gas test flame or an electric resistance (hot wire) device for the ignition source. Information on the type of samples and their average flash point are in the research report.<sup>10</sup>)

## 16. Precision and Bias (Procedure B)

16.1 *Precision*—The precision of this procedure as determined by the statistical examination of the interlaboratory test results, is as follows:

16.1.1 *Repeatability*—The difference between successive results obtained by the same operator with the same apparatus under constant operating conditions on identical test materials would, in the long run, in the normal and correct operation of the test method, exceed the following value in 1 case in 20:

$$\begin{array}{l} \text{Residual fuel oil } 2^{\circ}\text{C } (5^{\circ}\text{F}) \\ \text{Other types } 5^{\circ}\text{C } (9^{\circ}\text{F}) \end{array} \quad (6)$$

16.1.2 *Reproducibility*—The difference between two single and independent results obtained by different operators working in different laboratories on identical material would, in the long run, exceed the following value only in 1 case in 20.

$$\begin{array}{l} \text{Residual fuel oil } 6^{\circ}\text{C } (12^{\circ}\text{F}) \\ \text{Other types } 10^{\circ}\text{C } (18^{\circ}\text{F}) \end{array} \quad (7)$$

16.1.3 *Bias*—Since there is no accepted reference material suitable for determining the bias for the procedure in these test methods, bias has not been determined.

16.1.4 The precision data for residual fuel oils were developed in a 1996 cooperative test program conducted by the IP using 12 samples of residual fuel and 40 laboratories worldwide using both the manual and automated apparatus. Information on the type of samples and their average flash point are in the research report.

16.1.5 The precision data for other sample types in Procedure B is not known to have been developed in accordance with RR:D02–1007.<sup>11</sup>

NOTE 12—Procedure B was not tested in the 1991 interlaboratory program.

## 17. Keywords

17.1 automated flash point; automated Pensky-Martens closed cup; flammability; flash point; Pensky-Martens closed cup

<sup>10</sup> Supporting data (the results of the 1991 interlaboratory cooperative test program) have been filed at ASTM International Headquarters and may be obtained by requesting Research Report RR: S15–1008.

<sup>11</sup> Supporting data have been filed at ASTM International Headquarters and may be obtained by requesting Research Report RR: D02–1007.

ANNEXES

(Mandatory Information)

A1. APPARATUS SPECIFICATIONS

A1.1 A typical assembly of the apparatus, gas heated, is shown in Fig. A1.1. The apparatus shall consist of a test cup, cover, and stove conforming to the following requirements:

A1.1.1 *Cup*—The cup shall be of brass, or other nonrusting metal of equivalent heat conductivity, and shall conform to the dimensional requirements in Fig. A1.2. The flange shall be

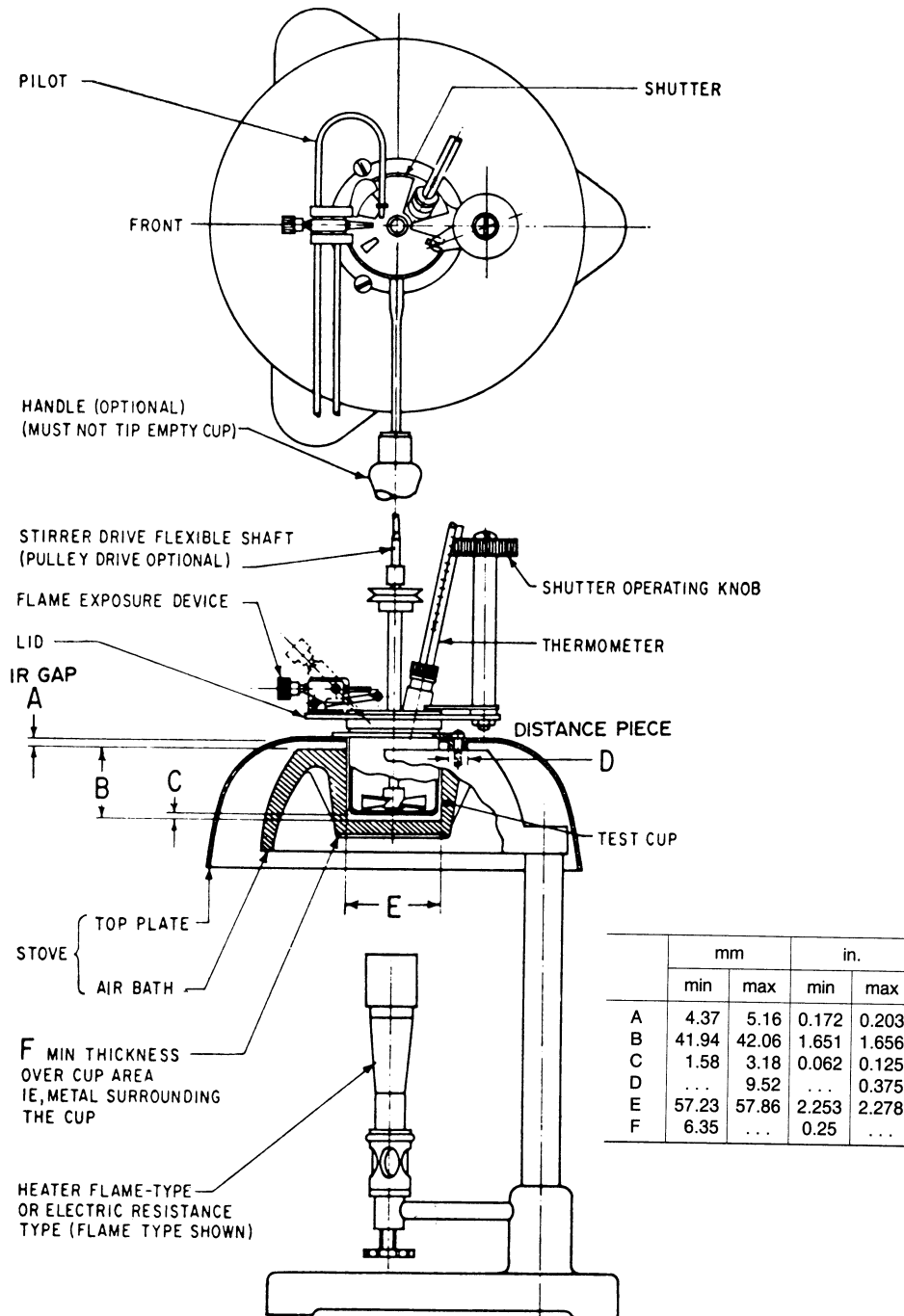

NOTE 1—Lid assembly can be positioned either right or left-handed.

FIG. A1.1 Pensky-Martens Closed Flash Tester

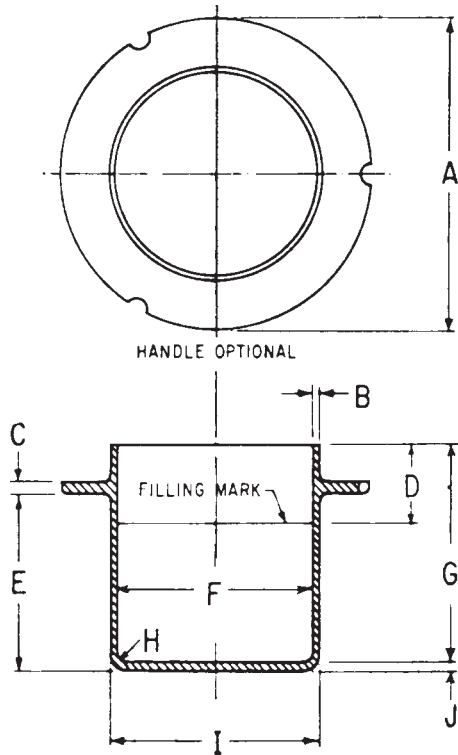

	mm		(in.)	
	min	max	(min)	(max)
A	79.0	79.8	(3.11)	(3.14)
B	1.0	...	(0.04)	(...)
C	2.8	3.6	(0.11)	(0.14)
D	21.72	21.84	(0.855)	(0.860)
E	45.47	45.72	(1.790)	(1.800)
F	50.72	50.85	(1.997)	(2.002)
G	55.75	56.00	(2.195)	(2.205)
H	3.8	4.0	(0.15)	(0.16)
I	53.90	54.02	(2.122)	(2.127)
J	2.29	2.54	(0.090)	(0.100)

FIG. A1.2 Test Cup

equipped with devices for locating the position of the cup in the stove. A handle attached to the flange of the cup is a desirable accessory. The handle shall not be so heavy as to tip over the empty cup.

A1.1.2 Cover:

A1.1.2.1 Cover Proper—The cover shown in Fig. A1.3 shall be of brass (A1.1.1) and shall have a rim projecting downward almost to the flange of the cup. The rim shall fit the outside of the cup with a clearance not exceeding 0.36 mm (0.014 in.) on the diameter. There shall be a locating or locking device, or both, engaging with a corresponding device on the cup. The four openings in the cover, A, B, C, and D, are shown in Fig. A1.3. The upper edge of the cup shall be in close contact with the inner face of the cover throughout its circumference.

A1.1.2.2 Shutter—The cover shall be equipped with a brass shutter (Fig. A1.1 and Fig. A1.4), approximately 2.4 mm (3/32 in.) thick, operating on the plane of the upper surface of the cover. The shutter shall be so shaped and mounted that it rotates on the axis of the horizontal center of the cover between two stops, so placed, that when in one extreme position, the

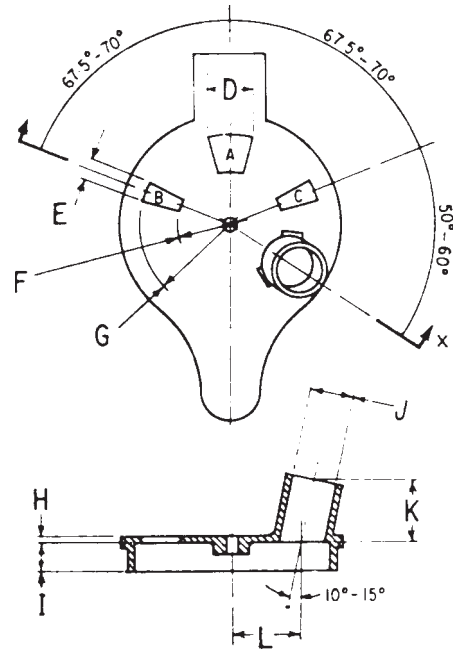

	mm		(in.)	
	min	max	(min)	(max)
D	12.7	13.5	(0.50)	(0.53)
E	4.8	5.6	(0.19)	(0.22)
F	13.5	14.3	(0.53)	(0.56)
G	23.8	24.6	(0.94)	(0.97)
H	1.2	2.0	(0.05)	(0.08)
I	7.9	...	(0.31)	(...)
J	12.00	12.32	(0.472)	(0.485)
K	16.38	17.00	(0.645)	(0.669)
L	18.65	19.45	(0.734)	(0.766)

FIG. A1.3 Cover Proper

openings A, B, and C in the cover are completely closed, and when in the other extreme position, these openings are completely opened. The mechanism operating the shutter should be of the spring type and constructed so that when at rest the shutter shall exactly close the three openings. When operated to the other extreme, the three cover openings shall be exactly open and the tip of the exposure tube shall be fully depressed.

A1.1.2.3 Flame-Ignition Device—The flame-ignition device (Fig. A1.4) shall have a tip with an opening 0.69 to 0.79 mm (0.027 to 0.031 in.) in diameter. This tip shall be made preferably of stainless steel, although it may be fabricated of other suitable metals. The flame-exposure device shall be equipped with an operating mechanism which, when the shutter is in the open position, depresses the tip so that the center of the orifice is between the planes of the under and upper surfaces of the cover proper at a point on a radius passing through the center of the larger opening A (Fig. A1.3). An electric ignitor is also suitable. The electric ignitors shall be of the electric resistance (hot-wire) type and shall position the heated section of the ignitor in the aperture of the test cover in the same manner as the gas flame device.

A1.1.2.4 Pilot Flame—A pilot flame shall be provided for automatic relighting of the exposure flame. A bead 4 mm (5/32 in.) in diameter can be mounted on the cover so that the



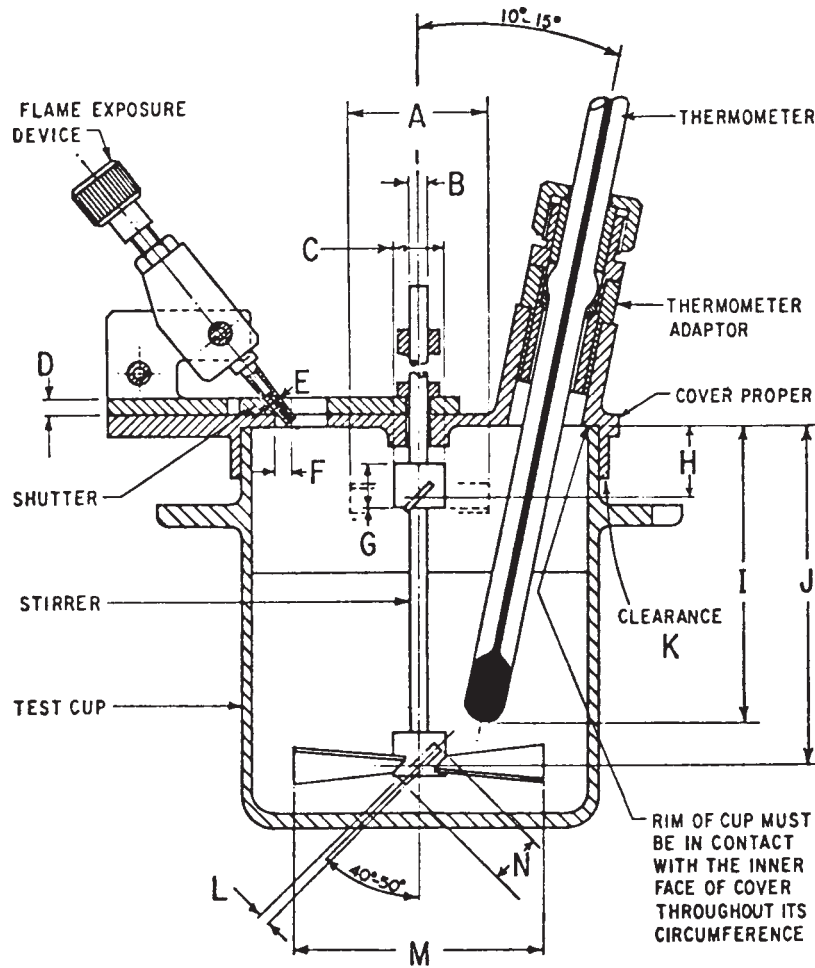

	mm		(in.)	
	min	max	(min)	(max)
A	18.3	19.8	(0.72)	(0.78)
B	2.38	3.18	(0.094)	(0.125)
C	7.6	8.4	(0.30)	(0.33)
D	2.0	2.8	(0.08)	(0.11)
E	0.69	0.79	(0.027)	(0.031)
F	2.0	2.8	(0.08)	(0.11)
G	6.4	10.4	(0.25)	(0.41)
H	9.6	11.2	(0.38)	(0.44)
I <sup>A</sup>	43.0	46.0	(1.69)	(1.81)
J	50.0	51.6	(1.97)	(2.03)
K	...	0.36	(...)	(0.014)
L	1.22	2.06	(0.048)	(0.08)
M	31.8	44.4	(1.25)	(1.75)
N	7.6	8.4	(0.30)	(0.33)

<sup>A</sup> Includes tolerance for length of thermometer given in Specification E 1.

FIG. A1.4 Test Cup and Cover Assembly

size of the test flame can be regulated by comparison. The tip of the pilot flame shall have an opening the same size as the tip of the flame exposure device (0.69 to 0.79 mm (0.027 to 0.031 in.) in diameter).

A1.1.2.5 *Stirring Device*—The cover shall be equipped with a stirring device (Fig. A1.4) mounted in the center of the cover and carrying two 2-bladed metal propellers. In Fig. A1.4 lower propeller is designated by the letters L, M, and N. This

propeller shall measure approximately 38 mm from tip to tip, with each of its two blades 8 mm in width with a pitch of 45°. The upper propeller is designated by the letters A, C, and G. This propeller measures approximately 19 mm, tip to tip, each of its two blades is also 8 mm in width with a pitch of 45°. Both propellers are located on the stirrer shaft in such a manner that, when viewed from the bottom of the stirrer, the blades of one propeller are at 0 and 180° while the blades of the other

propeller are at 90 and 270°. A stirrer shaft may be coupled to the motor by a flexible shaft or a suitable arrangement of pulleys.

A1.1.2.6 *Stove*—Heat shall be supplied to the cup by means of a properly designed stove which is equivalent to an air bath. The stove shall consist of an air bath and a top plate on which the flange of the cup rests.

A1.1.2.7 *Air Bath*—The air bath shall have a cylindrical interior and shall conform to the dimensional requirements in Fig. A1.1. The air bath may be either a flame or electrically heated metal casting (A1.1.2.8), or an electric-resistance element (A1.1.2.9). In either case, the air bath must be suitable for use at the temperatures to which it will be subjected without deformation.

A1.1.2.8 *Heater, Flame or Electric*—If the heating element is a flame or an electric heater, it shall be so designed and used that the temperatures of the bottom and the walls are approximately the same. In order that the air bath internal surfaces should be at a uniform temperature, it should not be less than

6.4 mm ( $\frac{1}{4}$  in.) in thickness unless the heating element is designed to give equal heat flux densities over all the wall and bottom surfaces.

A1.1.2.9 *Heater, Electric Resistance*—If the heater is of the electric resistance type, it shall be constructed so that all parts of the interior surface are heated uniformly. The wall and bottom of the air bath shall not be less than 6.4 mm ( $\frac{1}{4}$  in.) in thickness unless the resistance heating elements are distributed over at least 80 % of the wall and all the bottom of the air bath. A heater having such a distribution of the heating elements positioned at least 4.0 mm ( $\frac{5}{32}$  in.) away from the internal surface of the heating unit can be used in conjunction with a minimum thickness of 1.58 mm ( $\frac{1}{16}$  in.) for the wall and bottom of the air bath.

A1.1.2.10 *Top Plate*—The top plate shall be of metal, and shall be mounted with an air gap between it and the air bath. It may be attached to the air bath by means of three screws and spacing bushings. The bushings should be of proper thickness to define an air gap of 4.8 mm ( $\frac{3}{16}$  in.), and they shall be not more than 9.5 mm ( $\frac{3}{8}$  in.) in diameter.

## A2. MANUFACTURING STANDARDIZATION OF THERMOMETER AND FERRULE

A2.1 The low-range thermometer, which conforms also to the specification for the cup thermometer in the tag closed tester (Test Method D 56) and which frequently is fitted with a metal ferrule intended to fit the collar on the cover of the tag flash tester, can be supplemented by an adapter (Fig. A2.1) to be used in the larger diameter collar of the Pensky-Martens apparatus. Differences in dimensions of these collars, which do

not affect test results, are a source of unnecessary trouble to manufacturers and suppliers of instruments, as well as to users.

A2.2 Dimensional requirements are shown in Fig. A2.1. Conformity to these requirements is not mandatory, but is desirable to users as well as suppliers of Pensky-Martens testers.

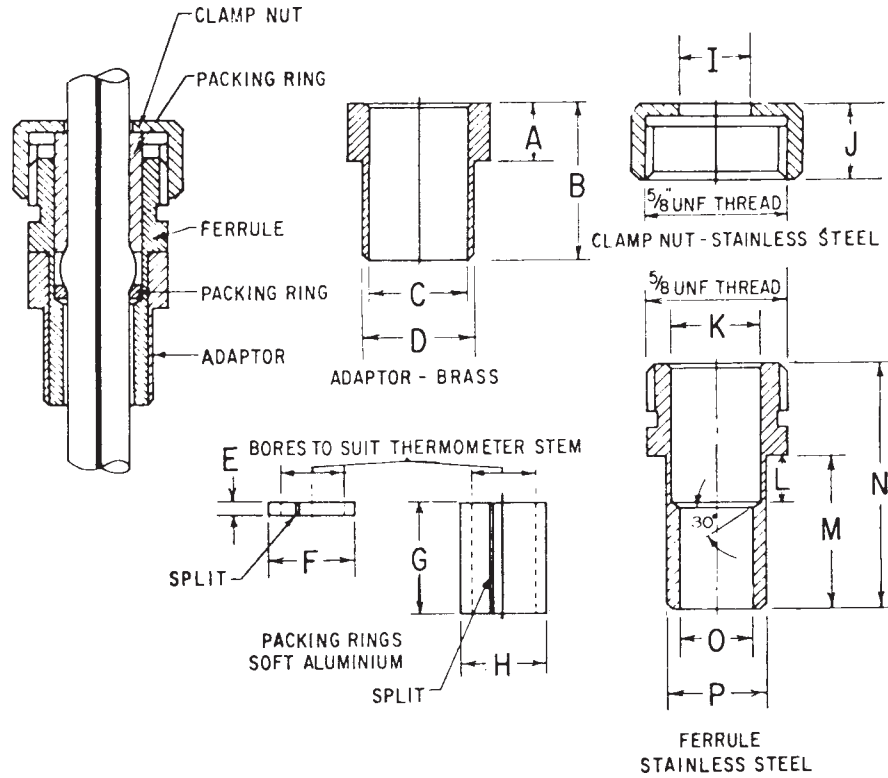

	mm		(in.)	
	min	max	(min)	(max)
A	6.20	6.50	(0.244)	(0.256)
B	17.0	18.0	(0.67)	(0.71)
C	9.80	9.85	(0.386)	(0.388)
D	11.92	12.24	(0.469)	(0.482)
E	1.40	1.65	(0.055)	(0.065)
F	8.56	8.61	(0.337)	(0.339)
G	12.4	13.0	(0.49)	(0.57)
H	8.56	8.61	(0.337)	(0.339)
I	8.1	8.6	(0.32)	(0.34)
J	9.9	10.7	(0.39)	(0.42)
K	8.64	8.69	(0.340)	(0.342)
L	5.1	5.6	(0.20)	(0.22)
M	17.0	17.5	(0.67)	(0.69)
N	27.4	28.2	(1.08)	(1.11)
O	7.11	7.16	(0.280)	(0.282)
P	9.73	9.78	(0.383)	(0.385)

FIG. A2.1 Dimensions for Thermometer Adapter, Ferrule, and Packing Ring

### A3. THERMOMETER SPECIFICATIONS

A3.1 See Fig. A3.1 and Tables A3.1-A3.4.

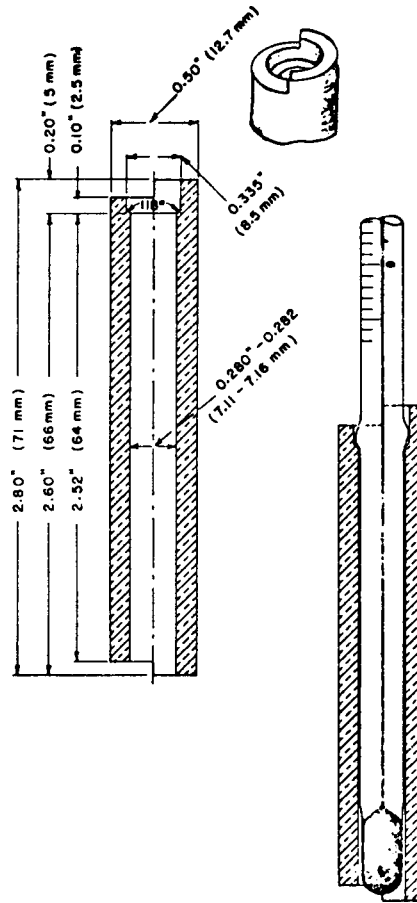

FIG. A3.1 Test Gage for Checking Enlargements on Thermometers

TABLE A3.1 IP Thermometer Specifications

NOTE—The stem shall be made with an enlargement having a diameter of 1.5 to 2.0 mm greater than the stem and a length of 3 to 5 mm, the bottom of the enlargement being 64 to 66 mm from the bottom of the bulb. These dimensions shall be measured with the test gage shown in Fig. A3.1.

Name	IP 15C	IP 16C	IP 101C
	Pensky-Martens Low	Pensky-Martens High	Pensky-Martens Medium
Range	-5 to + 110°C	90 to 370°C	20 to 150°C
Graduation	0.5°C	2°C	1°C
Immersion, mm	57	57	57
Overall length ±5 mm	290	280 ± 10	290
Stem diameter, mm	6.0 to 7.0	6.0 to 7.0	6.0 to 7.0
Bulb shape	cylindrical	cylindrical	cylindrical
Bulb length, mm	9 to 13	7 to 10	9 to 13
Bulb diameter, mm	not less than 5.5 and not greater than stem	not less than 4.5 and not greater than stem	not less than 5.5 and not greater than stem
Length of graduated portion, mm	140 to 175	143 to 180	140 to 175
Distance bottom of bulb to, mm	0°C 85 to 95	90°C 80 to 90	20°C 85 to 95
Longer lines at each	1 and 5°C	10 and 20°C	5°C
Figured at each	5°C	20°C	5°C
Expansion chamber	required	required	required
Top finish	ring	ring	ring
Scale error not to exceed ±	0.5°C	1 to 260°C 2°C above 260°C	1°C
See notes	1 and Table A3.2 for emergent stem temperatures	1 and Table A3.2 for emergent stem temperatures	1 and Table A3.2 for emergent stem temperatures





**TABLE A3.2 Specifications for ASTM Thermometers**  
All dimensions are in millimetres.  
See Table A3.3 for Standardization Temperature.

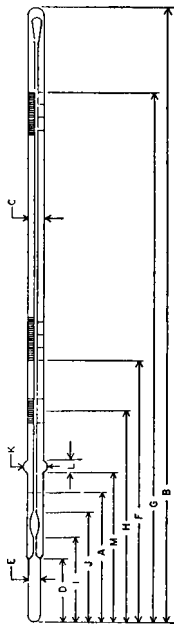

ASTM Number and Name	Range	For Test at	Im-mer-sion	Graduations			Scale Error, max	Special In-scrip-tion	Expan-sion Cham-ber	Total Length ±5	Stem OD	Bulb		Scale Location				Ice Point Scale		Contraction Chamber		Stem Enlargement	
				Sub-divisions	Long Lines at Each	Num-ber at Each						Length	OD	Bot-tom of Bulb to Line at	Dis-tance	Bot-tom of Bulb to Line at	Dis-tance	Range	Bot-tom of Bulb to Ice Point	Dis-tance to Bot-tom, min	Dis-tance to Top, max	OD	Length
9C-62	-5 to +110°C		57	0.5°C	1°C	5°C	0.5°C	ASTM	160°C	287	6.0	D	E	F	G	H		I	J	K	L	M	
Pensky-Martens Low-Range Tag Closed Tester 9F-62	(20 to 230°F)			1°F	5°F	10°F	1°F	9C or 9F 57 mm IMM	320°F		7.0	13	not greater than stem	85 to 98	221 to 237					7.5 to 8.5	2.5 to 5.0 <sup>A</sup>	64 to 66	
10C-62 Pensky-Martens High-Range 10F-62	90 to 370°C (200 to 700°F)		57	2°C	10°C	20°C	<sup>B</sup>	ASTM 10C or 10F 57 mm IMM	<sup>C</sup>	287	6.0 to 7.0	8.0 to 10.0	4.5 to 6.0	86 to 99	227 to 245	360°C 680°F	110°C 230°F			7.5 to 8.5	2.5 to 5.0 <sup>A</sup>	64 to 66	

<sup>A</sup> The length of the enlargement, and the distance from the bottom of the enlargement to the bottom of the bulb shall be measured with the test gage shown in Fig. A3.1.

<sup>B</sup> Scale error: 1°C up to 260°C; 2°C over 260°C.

<sup>C</sup> An expansion chamber is provided for relief of gas pressure to avoid distortion of the bulb at higher temperatures. It is not for the purpose of joining mercury separations; and under no circumstances should the thermometer be heated above the highest temperature reading.

<sup>D</sup> Scale error: 2.5°F up to 500°F; 3.5°F over 500°F.



**TABLE A3.3 Standardization Temperatures**

NOTE—The emergent column temperatures are those attained when using the thermometers in the test equipment for which the thermometers were originally designed. In some cases these temperatures are markedly different from those realized during standardization.

Temperature	Average Temperature of Emergent Column	Temperature	Average Temperature of Emergent Column	Temperature	Average Temperature of Emergent Column	Temperature	Average Temperature of Emergent Column
Thermometer 9C (-5 to + 100°C)		Thermometer 9F (20 to 230°F)		Thermometer 10C (90 to 370°C)		Thermometer 10F (200 to 700°F)	
0°C	19°C	32°F	66°F	100°C	61°C	212°F	141°F
35°C	28°C	100°F	86°F	200°C	71°C	390°F	159°F
70°C	40°C	160°F	106°F	300°C	87°C	570°F	180°F
105°C	50°C	220°F	123°F	370°C	104°C	700°F	220°F
IP 15C (-7 to 110°C)		IP 15F (20 to 230°F)		IP 16C (90 to 370°C)		IP 16F (20 to 700°F)	
0°C	19°C	32°F	66°F	100°C	61°C	200°F	140°F
20°C	20°C	70°F	70°F	150°C	65°C	300°F	149°F
40°C	31°C	100°F	86°F	200°C	71°C	400°F	160°F
70°C	40°C	150°F	104°F	250°C	78°C	500°F	175°F
100°C	48°C	212°F	118°F	300°C	87°C	600°F	195°F
				350°C	99°C	700°F	220°F

**TABLE A3.4 Specifications for Medium-Range Pensky-Martens**

ASTM No. 88F (88C) Vegetable Oil Flash Thermometer		Medium-Range Pensky-Martens	
Name		5	
Reference Fig. No.		5	
Range	10–200°C	50–392°F	
For test at			
A Immersion, mm		57	
Graduations:			
Subdivisions	0.5°C	1°F	
Long lines at each	1°C and 5°C	5°F	
Numbers at each	5°C	10°F	
Scale error, max	0.5°C	1°F	
Special inscription		ASTM 88F (88C) 57 mm IMM	
Expansion chamber:			
Permit heating to	205°C	400°F	
B Total length, mm		285 to 295	
C Stem OD, mm		6.0 to 7.0	
D Bulb length, mm		8.0 to 12.0	
E Bulb OD, mm		>4.5 and <stem <sup>A</sup>	
Scale location:			
Bottom of bulb to line at	20°C	68°F	
F Distance, mm		80 to 90	
G Length of graduated portion, mm		145 to 180	
Ice-point scale:			
Range			
H Bottom of bulb to ice-point, mm			
Contraction chamber:			
I Distance to bottom, min, mm			
J Distance to top, max, mm			
Stem enlargement:			
K OD, mm		7.5 to 8.5	
L Length, mm		2.5 to 5.0 <sup>A</sup>	
M Distance to bottom, mm		64 to 66	

<sup>A</sup> Bulb OD shall be greater than 4.5 mm and less than the outside diameter of the stem (C).

#### A4. VERIFICATION OF APPARATUS PERFORMANCE

A4.1 *Certified Reference Material (CRM)*—CRM is a stable, pure (99 + mole % purity) hydrocarbon or other stable petroleum product with a method-specific flash point established by a method-specific interlaboratory study following ASTM RR:D02-1007 guidelines<sup>11</sup> or ISO Guide 34 and 35.

A4.1.1 Values of the flash point corrected for barometric pressure for some reference materials and their typical limits are given in Table A4.1<sup>12</sup> (see Note A4.1). Suppliers of CRMs

**TABLE A4.1 D 93 Typical Flash Point Values and Typical Limits for CRM**

NOTE—Supporting data for the interlaboratory study to generate the flash point in Table A4.1 can be found in research report RR:S15-1010.<sup>12</sup>

Hydrocarbon	Purity, mole %	Flash Point, °C	Limits, °C
<i>n</i> -decane	99 +	52.8	±2.3
<i>n</i> -undecane	99 +	68.7	±3.0
<i>n</i> -tetradecane	99 +	109.3	±4.8
<i>n</i> -hexadecane	99 +	133.9	±5.9

<sup>12</sup> Supporting data have been filed at ASTM International Headquarters and may be obtained by requesting Research Report RR: S15-1010.

will provide certificates stating the method-specific flash point for each material of the current production batch. Calculation of the limits for these other CRMs can be determined from the reproducibility value of these test methods, reduced by interlaboratory effect and then multiplied by 0.7. See Research Report RR:S15-1008.<sup>10</sup>

NOTE A4.1—Materials, purities, flash point values, and limits stated in Table A4.1 were developed in an ASTM interlaboratory program to determine suitability of use for verification fluids in flash point test methods. Other materials, purities, flash point values, and limits can be suitable when produced according to the practices of ASTM RR:D02-1007 or ISO Guides 34 and 35. Certificates of performance of such materials should be consulted before use, as the flashpoint value will vary dependent on the composition of each CRM batch.

A4.2 *Secondary Working Standard (SWS)*—SWS is a stable, pure (99 + mole % purity) hydrocarbon, or other petroleum product whose composition is known to remain appreciably stable.

A4.2.1 Establish the mean flash point and the statistical control limits ( $3\sigma$ ) for the SWS using standard statistical techniques. (See ASTM MNL 7).<sup>13</sup>

<sup>13</sup> *Manual on Presentation of Data and Control Chart Analysis, ASTM MNL*, 6th ed., ASTM International, W. Conshohocken, 1990.

## APPENDIXES

### (Nonmandatory Information)

#### X1. FLASH POINT MASKING PHENOMENON

X1.1 A condition during flash point testing can occur with certain mixtures whereby the nonflammable component of the sample tends to inert the vapor space above the liquid, thus preventing a flash. Under this condition, the flash point of the material is masked resulting in the reporting of incorrect high flash point or no flash point.

X1.2 This flash point masking phenomenon most frequently occurs with ignitable liquids that contain certain halogenated hydrocarbons such as dichloromethane (methylene chloride) and trichloroethylene.

X1.3 Under this condition, no distinct flash as defined in 3.1.3 of these test methods is observed. Instead a significant enlargement of the test flame and a change in the color of the

test flame from blue to yellow-orange laminar flame is observed.

X1.4 Under this condition, continued heating and testing for flash point at temperatures above ambient temperature, have resulted in significant burning of the ignitable vapor outside the test cup, often above the test flame. This can be a potential fire hazard if not recognized.

X1.5 It is recommended that if this condition is encountered during the flash point testing of these type of materials, testing should be discontinued.

X1.6 Further commentaries regarding flash point test and flammability of mixtures can be found in Test Method E 502.

## X2. FLASH POINT TEST AND FLAMMABILITY OF MIXTURES

X2.1 While the flash point can be used to indicate the flammability of liquid materials for certain end uses, flash point does not represent the minimum temperature at which a material can evolve flammable vapors.

X2.2 There are instances with pure materials where the absence of a flash point does not ensure freedom from flammability. Included in this category are materials that require large diameters for flash propagation, such as trichloroethylene. This material will not propagate a flame in apparatus the size of a flash point tester, however, its vapors are flammable and will burn when ignited in apparatus of adequate size.

X2.3 When a liquid contains flammable and nonflammable

components, there are cases where this liquid can evolve flammable vapors under certain conditions and yet will not exhibit a close-cup flash point. This phenomenon is noted when a nonflammable component is sufficiently volatile and present in sufficient quantity to inert the vapor space of the closed cup, thus preventing a flash. In addition, there are certain instances where an appreciable quantity of the nonflammable component will be present in the vapor, and the material will exhibit no flash point.

X2.4 Liquids containing a highly volatile nonflammable component or impurity, which exhibit no flash point because of the influence of the nonflammable material, may form flammable mixtures if totally flash vaporized in air in the proper proportions.

## SUMMARY OF CHANGES

Subcommittee D02.08 has identified the location of selected changes to this standard since the last issue (D 93-02) that may impact the use of this standard.

- (1) Added a paragraph to the Introduction about flash point values being dependent on the test procedure used.      (2) Deleted Note 2 and renumbered the notes.

*ASTM International takes no position respecting the validity of any patent rights asserted in connection with any item mentioned in this standard. Users of this standard are expressly advised that determination of the validity of any such patent rights, and the risk of infringement of such rights, are entirely their own responsibility.*

*This standard is subject to revision at any time by the responsible technical committee and must be reviewed every five years and if not revised, either reapproved or withdrawn. Your comments are invited either for revision of this standard or for additional standards and should be addressed to ASTM International Headquarters. Your comments will receive careful consideration at a meeting of the responsible technical committee, which you may attend. If you feel that your comments have not received a fair hearing you should make your views known to the ASTM Committee on Standards, at the address shown below.*

*This standard is copyrighted by ASTM International, 100 Barr Harbor Drive, PO Box C700, West Conshohocken, PA 19428-2959, United States. Individual reprints (single or multiple copies) of this standard may be obtained by contacting ASTM at the above address or at 610-832-9585 (phone), 610-832-9555 (fax), or service@astm.org (e-mail); or through the ASTM website (www.astm.org).*